



60 Cohoes Ave. Green Island, NY 12183 • www.gemlockgrooved.com

SUBMITTAL FORM

This packet contains engineering and product information specific to the following project:

PROJECT INFORMATION

Project:	Project Address:
Architect:	Engineer:
Contractor:	Submittal Date:

APPROVER INSTRUCTIONS

Approved	Approved as Noted	Not Approved
Remarks:		

PRODUCT INDEX The following products are included in this submittal (please check all that apply)

GROOVED COUPLINGS

- Rigid Coupling Style 5
- Rigid Coupling Style 5A
- Flexible Coupling Style 12
- Reducing Coupling Style 25
- Rigid Coupling Style 99
- Rigid Coupling Style 99-2

FLANGE ADAPTER

- Flange Adapter Style 14
- Flange Adapter Nipple Style F190
- Flange Adapter Insert Style 20

MECHANICAL TEES

- Tee Lock Style 13
- Tee Lock Style 13A
- Mechanical Tee (GRV) Style 15
- Mechanical Tee (THD) Style 16
- Mechanical Tee (GRV) Style 35

GROOVED FITTING

SHORT PATTERN

- 90° Elbow Style F105
- 45° Elbow Style F106
- Tee Style F107
- Cross Style F135
- Reducing Tee Style 115

CAPS

- End Cap Style 150
- Drain Cap Style F155D

STANDARD REDUCERS

- Concentric Grooved Style 140
- Eccentric Grooved Style 145

STANDARD PATTERN FITTINGS

- 90° Elbow Style 100
- 45° Elbow Style F102
- 22-1/2° Elbow Style 102
- 11-1/4° Elbow Style 103
- Drain Elbow Style F100D
- Drain Tee Style F115D
- Tee Style 110
- 90° Adapter ELL Style 105TL

GROOVED VALVES

- | | |
|--|--|
| Grooved End Swing Check Valve
Model LVCVGG-400 | Wafer Butterfly Valve with Tamper
Model LVWBG |
| Grooved End Check Valve with
Inspection Cover
Models LVCVGG-RF | Powerball
Models LPBT & LPBG |
| Riser Check Valve
Model LVRCGG | Lever Handle Butterfly Valve
Model LV-GTV |
| | Grooved Butterfly Valve
Model LVBG1 & LVBG3 |

RIGID COUPLING STYLE 5



UL Listed
Under File No. EX15592

- **Housing:** Ductile Iron conforming to ASTM A536, Grade 65-45-12
- **Bolts/Nuts:** Zinc electroplated carbon steel oval neck track head bolts conforming to ASTM A183 Grade 2 and SAE J429 Grade 5 with a minimum tensile strength of 110,000 psi. Zinc electroplated carbon steel heavy hex nut conforming to ASTM A536, Grade A.
- **Coatings:** Rust inhibiting orange paint (Standard) or Hot Dipped Galvanized (Optional) conforming to ASTM A153
- **Gasket Material:** Pre-Lubricated Grade “E” EPDM, Approved and Listed for use in Wet or Dry Systems
- **Gasket Temperature Range:** -40°F to 230°F (Service temperature range)
- **Lubrication:** Supplemental lubricant is recommended for services below 0°F and for all dry pipe systems or systems to be subjected to air tests prior to being filled with water.
- **Sizes:** 1” to 12”
- **Maximum Working Pressure:** 300 psi

Available with a GemSeal EPDM gasket specifically designed for use in a dry fire sprinkler piping system, and will prohibit the build-up of contaminants within the gasket cavity if used in other types of piping systems. This gasket has a centering rib that fits over the pipe ends, closing off the gasket cavity.

The Style 5 Coupling is our standard coupling and is designed for joint rigidity, providing a “weld like joint”. Conforms to the requirements of ANSI B31.1 Power Piping Code; ANSI B31.9 Building Service Pipe Code and NFPA13 sprinkler systems.

Before installing, please read the Installation Instructions.

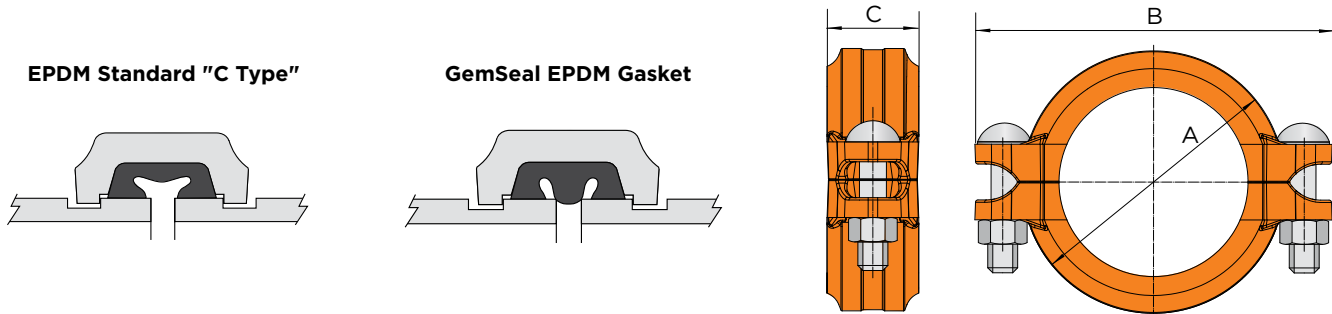

RIGID COUPLING STYLE 5								
Pipe		Max. Working Pressure (psi)*	Allow Pipe End Separation (in.)	Dimensions (in.)			Bolt Size (in.)	Approx. Weight Each (lb.)
Nominal Size (in.)	Actual Size (in.)			A	B	C		
1	1.315	300	0.1	2.36	4.02	1.77	3/8 x 1-3/4	1.2
1-1/4	1.66	300	0.1	2.76	4.17	1.73	3/8 x 1-3/4	1.31
1-1/2	1.9	300	0.1	2.87	4.25	1.73	3/8 x 1-3/4	1.26
2	2.375	300	0.1	3.43	4.84	1.73	3/8 x 2-3/16	1.47
2-1/2	2.875	300	0.1	3.94	5.43	1.73	3/8 x 2-3/16	1.76
3	3.5	300	0.1	4.61	6.54	1.77	1/2 x 2-3/8	2.41
4	4.5	300	0.16	5.47	7.48	1.93	1/2 x 2-1/2	2.93
5	5.563	300	0.16	6.58	8.62	1.93	1/2 x 3	3.55
6	6.625	300	0.16	7.82	9.80	1.97	1/2 x 3	4.73
8	8.625	300	0.19	9.96	12.60	2.32	7/8 x 4-3/4	8.15
10	10.75	300	0.19	13.19	16.77	2.56	7/8 x 5-1/8	17.08
12	12.75	300	0.20	14.96	18.50	2.60	7/8 x 5-1/8	24.5

PROJECT	APPROVAL STAMP
PROJECT:	<input type="checkbox"/> APPROVED
ADDRESS:	<input type="checkbox"/> APPROVED AS NOTED
ENGINEER:	<input type="checkbox"/> NOT APPROVED
SUBMITTAL DATA:	REMARKS:
NOTES 1:	
NOTES 2:	



60 Cohoes Ave. Green Island, NY 12183 • www.gemlockgrooved.com

RIGID COUPLING - ANGLE PATTERN

STYLE 5A



UL Listed
Under File No. EX15592

- **Housing:** Ductile Iron conforming to ASTM A536, Grade 65-45-12
- **Bolts/Nuts:** Zinc electroplated carbon steel oval neck track head bolts conforming to ASTM A183 Grade 2 and SAE J429 Grade 5 with a minimum tensile strength of 110,000 psi. Zinc electroplated carbon steel heavy hex nut conforming to ASTM A536, Grade A.
- **Coatings:** Rust inhibiting orange paint (Standard) or Hot Dipped Galvanized (Optional) conforming to ASTM A153
- **Gasket Material:** Pre-Lubricated Grade “E” EPDM, Approved and Listed for use in Wet or Dry Systems
- **Gasket Temperature Range:** -40°F to 230°F (Service temperature range)
- **Lubrication:** Supplemental lubricant is recommended for services below 0°F and for all dry pipe systems or systems to be subjected to air tests prior to being filled with water.
- **Sizes:** 1” to 12”
- **Maximum Working Pressure:** 300 psi

The Style 5A Coupling is our standard coupling and is designed for joint rigidity, providing a “weld like joint”. Conforms to the requirements ANSI B31.1 Power Piping Code; ANSI B31.9 Building Service Pipe Code and NFPA13 sprinkler systems.

Before installing, please read the Installation Instructions.

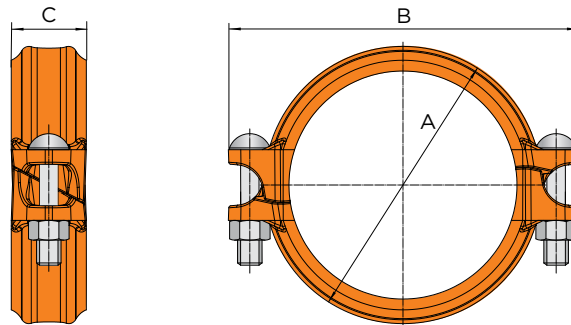

RIGID COUPLING - ANGLE PATTERN STYLE 5A							
Pipe		Max. Working Pressure (psi)*	Dimensions (in.)			Bolt Size (in.)	Approx. Weight Each (lb.)
Nominal Size (in.)	Actual Size (in.)		A	B	C		
1-1/4	1.66	300	2.60	4.17	1.85	3/8 x 2-3/16	1.31
1-1/2	1.90	300	2.78	4.37	1.85	3/8 x 2-3/16	1.20
2	2.375	300	3.35	4.86	1.85	3/8 x 2-3/8	1.47
2-1/2	2.875	300	3.90	5.41	1.85	3/8 x 2-3/8	1.67
3	3.50	300	4.61	6.48	1.87	1/2 x 2-1/2	2.42
4	4.50	300	5.53	7.40	2.05	1/2 x 2-3/4	2.93
5	5.563	300	6.60	8.62	2.05	1/2 x 2-3/4	4.40
6	6.625	300	7.60	9.57	2.07	1/2 x 2-3/4	4.73
8	8.625	300	9.88	12.60	2.52	5/8 x 4-3/8	8.23
10	10.75	300	12.44	15.75	2.60	7/8 x 6-1/8	17.04
12	12.75	300	14.82	18.27	2.60	1 x 6-1/2	21.87

PROJECT	APPROVAL STAMP
PROJECT:	<input type="checkbox"/> APPROVED
ADDRESS:	<input type="checkbox"/> APPROVED AS NOTED
ENGINEER:	<input type="checkbox"/> NOT APPROVED
SUBMITTAL DATA:	REMARKS:
NOTES 1:	
NOTES 2:	

ONE-BOLT PUSH-ON COUPLING STYLE 99



- **Housing:** Ductile Iron conforming to ASTM A536, Grade 65-45-12
- **Bolts/Nuts:** Zinc electroplated carbon steel oval neck track head bolts conforming to ASTM A183 Grade 2 and SAE J429 Grade 5 with a minimum tensile strength of 110,000 psi. Zinc electroplated carbon steel heavy hex nut conforming to ASTM A536, Grade A.
- **Coatings:** Rust inhibiting orange paint (Standard) or Hot Dipped Galvanized (Optional) conforming to ASTM A153
- **Gasket Material:** Pre-Lubricated Grade "E" EPDM, Approved and Listed for use in Wet or Dry Systems
- **Gasket Temperature Range:** -40°F to 230°F (Service temperature range)
- **Lubrication:** Supplemental lubricant is recommended for services below 0°F and for all dry pipe systems or systems to be subjected to air tests prior to being filled with water.
- **Sizes:** 1" to 6"
- **Maximum Working Pressure:** Schedule 10/40 365 psi, Schedule 7 300 psi

The Style 99 Push-On Coupling is an advanced rigid grooved coupling designed to connect grooved joints (whether rolled or cut) to standard grooved specifications for steel pipes. This innovative coupling utilizes two ductile iron housings that lock together with a single bolt, eliminating the need to disassemble the coupling for installation (refer to the next page for installation instructions).

This design significantly speeds up the installation process, resulting in a more economical solution for joining grooved piping and reducing overall installation costs for any grooved piping project.

Before installing, please read the Installation Instructions.

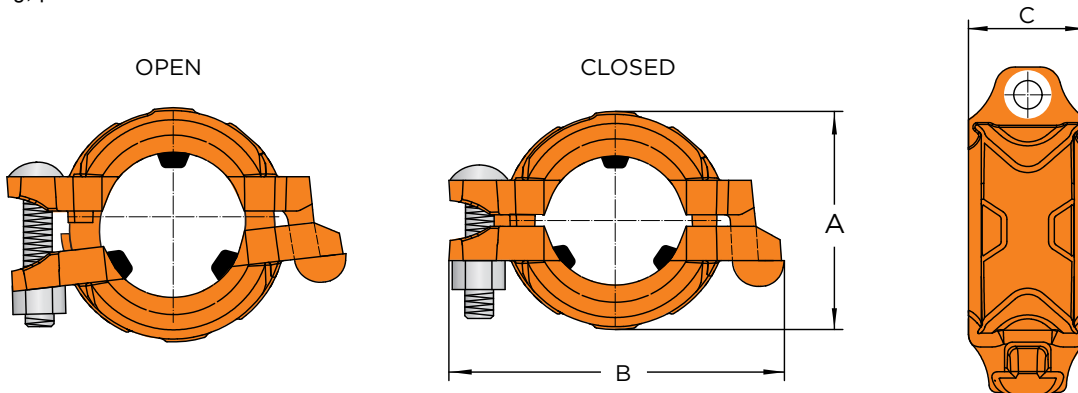

ONE-BOLT, PUSH-ON COUPLING STYLE 99						
Nominal Size (in.)	Pipe O.D. (in.)	Dimensions L (in.)			Bolt Size (in.)	Weight (lbs.)
		A	B	C		
1	1.32	2.35	4.0	1.81	3/8 x 2-3/16	1.18
1-1/4	1.67	2.68	4.34	1.81	3/8 x 2-3/8	1.24
1-1/2	1.9	3.0	4.60	1.81	3/8 x 2-3/8	1.30
2	2.37	3.50	5.08	1.81	3/8 x 2-1/2	1.52
2-1/2	2.87	3.84	5.55	1.81	3/8 x 2-3/4	1.87
3	3.5	4.47	6.61	1.81	1/2 x 3-1/8	2.27
4	4.5	5.60	7.72	1.89	1/2 x 3-1/8	3.09
5	5.56	6.75	9.02	2.03	1/2 x 3-3/8	3.55
6	6.63	8.03	10.24	2.17	1/2 x 3-1/2	5.28

PROJECT		APPROVAL STAMP
PROJECT:		<input type="checkbox"/> APPROVED
ADDRESS:		<input type="checkbox"/> APPROVED AS NOTED
ENGINEER:		<input type="checkbox"/> NOT APPROVED
SUBMITTAL DATA:		REMARKS:
NOTES 1:		
NOTES 2:		

TWO-BOLT ANGLE PATTERN PUSH-ON COUPLING STYLE 99-2



UL Listed
Under File No. EX15592

- **Housing:** Ductile Iron conforming to ASTM A536, Grade 65-45-12
- **Bolts/Nuts:** Zinc electroplated carbon steel oval neck track head bolts conforming to ASTM A183 Grade 2 and SAE J429 Grade 5 with a minimum tensile strength of 110,000 psi. Zinc electroplated carbon steel heavy hex nut conforming to ASTM A536, Grade A.
- **Coatings:** Rust inhibiting orange paint (Standard) or Hot Dipped Galvanized (Optional) conforming to ASTM A153
- **Gasket Material:** Pre-Lubricated EPDM, when installed the center stop of the gasket offers the same performance characteristics as a GemSeal gasket which is often required for dry systems. Gasket Approved and Listed for use in Wet or Dry Systems.
- **Gasket Temperature Range:** -40°F to 230°F (Service temperature range)
- **Lubrication:** Supplemental lubrication is recommended for services below 0°F and for all dry pipe systems, or systems that will be subjected to an air test prior to being filled with water.
- **Sizes:** 1" to 8"
- **Maximum Working Pressure:** 300 psi

The Style 99-2, Two-Bolt Angle Pattern Push-On Rigid Coupling designed to connect grooved joints (whether rolled or cut) to standard grooved specifications for steel pipes. This innovative coupling utilizes two ductile iron housings that lock together, eliminating the need to disassemble the coupling for installation.

This design significantly speeds up the installation process, resulting in a more economical solution for joining grooved piping and reducing overall installation costs for any grooved piping project.

Before installing, please read the Installation Instructions.

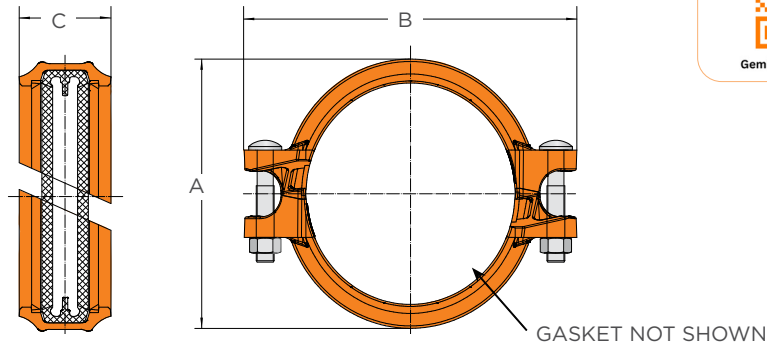

TWO-BOLT ANGLE PATTERN, PUSH-ON COUPLING STYLE 99-2

Nominal Size (in.)	Pipe O.D. (in.)	Dimensions (in.)			Bolt Size (in.)	Weight (lbs.)
		A	B	C		
1	1.32	2.48	3.74	1.85	3/8 x 2-3/16	1.19
1-1/4	1.67	2.83	4.09	1.85	3/8 x 2-3/16	1.25
1-1/2	1.9	3.03	4.37	1.85	3/8 x 2-3/16	1.30
2	2.37	3.58	4.84	1.85	3/8 x 2-3/16	1.56
2-1/2	2.87	4.06	5.39	1.85	3/8 x 2-3/8	1.80
3	3.5	4.69	6.10	1.91	3/8 x 2-3/8	2.16
4	4.5	5.87	7.28	2.03	1/2 x 2-1/2	2.97
5	5.56	7.01	8.46	2.05	1/2 x 3	3.92
6	6.63	8.07	9.61	2.07	1/2 x 3-1/8	4.55
8	8.63	10.39	12.44	2.52	5/8 X 4	8.89

PROJECT		APPROVAL STAMP
PROJECT:		<input type="checkbox"/> APPROVED
ADDRESS:		<input type="checkbox"/> APPROVED AS NOTED
ENGINEER:		<input type="checkbox"/> NOT APPROVED
SUBMITTAL DATA:		REMARKS:
NOTES 1:		
NOTES 2:		



60 Cohoes Ave. Green Island, NY 12183 • www.gemlockgrooved.com

FLEXIBLE COUPLING

STYLE 12



UL Listed
Under File No. EX15592

- **Housing:** Ductile Iron conforming to ASTM A536, Grade 65-45-12
- **Bolts/Nuts:** Zinc electroplated carbon steel oval neck track head bolts conforming to ASTM A183 Grade 2 and SAE J429 Grade 5 with a minimum tensile strength of 110,000 psi. Zinc electroplated carbon steel heavy hex nut conforming to ASTM A536, Grade A.
- **Coatings:** Rust inhibiting orange paint (Standard) or Hot Dipped Galvanized (Optional) conforming to ASTM A153
- **Gasket Material:** Pre-Lubricated Grade "E" EPDM, Approved and Listed for use in Wet or Dry Systems
- **Gasket Temperature:** Range: -40°F to 230°F (Service temperature range)
- **Lubrication:** Supplemental lubricant is recommended for services below 0°F and for all dry pipe systems or systems to be subjected to air tests prior to being filled with water.
- **Sizes:** 1" to 12"
- **Maximum Working Pressure:** 300 psi

The Gemlock Style 12 Flexible Coupling is approved for use in both wet and dry fire sprinkler systems. The Style 12 Coupling is our flexible lightweight coupling designed for fire protection services. Conforms to the requirements ANSI B31.1 Power Piping Code; ANSI B31.9 Building Service Pipe Code and NFPA13 sprinkler systems.

Before installing, please read the Installation Instructions.

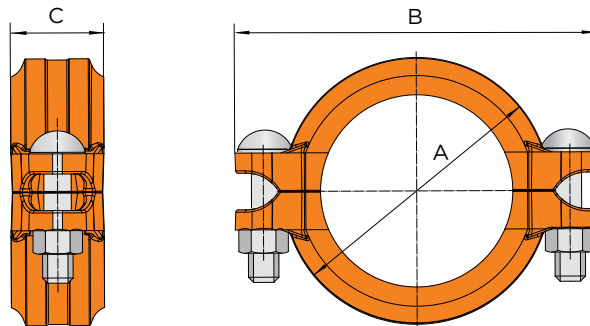

FLEXIBLE COUPLING STYLE 12

Pipe		Max. Working Pressure (psi)*	Allow Pipe End Separation (in.)	Max Deflection from Center Line		Dimensions (in.)			Bolt Size	Approx. Weight Each (lb.)
Nominal Size (in.)	Actual Size (in.)			A	B	C				
1	1.315	300	0.1	5°-26'	1.14	2.36	3.86	1.71	3/8 x 1-3/4	1.2
1-1/4	1.66	300	0.1	4°-19'	0.9	2.63	4.17	1.732	3/8 x 1-3/4	1.30
1-1/2	1.9	300	0.1	3°-46'	0.79	2.87	4.25	1.732	3/8 x 1-3/4	1.27
2	2.375	300	0.1	3°-1'	0.62	3.43	4.84	1.732	3/8 x 2-3/16	1.48
2-1/2	2.875	300	0.1	2°-29'	0.52	3.94	5.43	1.732	3/8 x 2-3/16	1.71
3	3.5	300	0.1	2°-3'	0.43	4.61	6.35	1.77	1/2 x 2-3/8	2.44
4	4.5	300	0.16	3°-11'	0.67	5.47	7.48	1.929	1/2 x 2-1/2	2.89
5	5.563	300	0.16	2°-35'	0.54	6.61	8.58	1.929	1/2 x 3	3.58
6	6.625	300	0.16	2°-10'	0.46	7.82	9.49	1.929	1/2 x 3	4.73
8	8.625	300	0.19	1°-40'	0.34	9.96	12.60	2.323	1/2 x 3-3/8	7.91
10	10.75	300	0.19	0°-95'	0.13	12.48	15.79	2.48	7/8 x 5-1/8	16.95
12	12.75	300	0.20	0°-23'	0.12	14.76	17.91	2.52	7/8 x 5-1/8	24.0

PROJECT	APPROVAL STAMP
PROJECT:	<input type="checkbox"/> APPROVED
ADDRESS:	<input type="checkbox"/> APPROVED AS NOTED
ENGINEER:	<input type="checkbox"/> NOT APPROVED
SUBMITTAL DATA:	REMARKS:
NOTES 1:	
NOTES 2:	

REDUCING COUPLING STYLE 25



UL Listed
Under File No. EX15592

- **Housing:** Ductile Iron conforming to ASTM A536, Grade 65-45-12
- **Bolts/Nuts:** Zinc electroplated carbon steel oval neck track head bolts conforming to ASTM A183 Grade 2 and SAE J429 Grade 5 with a minimum tensile strength of 110,000 psi. Zinc electroplated carbon steel heavy hex nut conforming to ASTM A536, Grade A.
- **Coatings:** Rust inhibiting orange paint (Standard) or Hot Dipped Galvanized (Optional) conforming to ASTM A153
- **Gasket Material:** Pre-Lubricated Grade "E" EPDM, Approved and Listed for use in Wet or Dry Systems
- **Gasket Temperature Range:** -40°F to 230°F (Service temperature range)
- **Lubrication:** Supplemental lubricant is recommended for services below 0°F and for all dry pipe systems or systems to be subjected to air tests prior to being filled with water.
- **Sizes:** 1-1/2" to 8"
- **Maximum Working Pressure:** 300 psi

The Style 25 Reducing Coupling allows for direct connection of two different pipe sizes, eliminating the need for two couplings and a concentric reducer. The steel washer prevents telescoping of the smaller pipe inside the larger pipe during vertical system assembly.

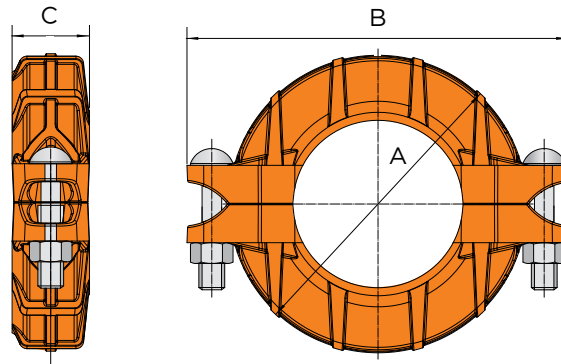

REDUCED COUPLING STYLE 25

Pipe Nominal Size (in.)	Max. Working Pressure (psi)	Allow Pipe End Separation (in.)	Max. Deduction from Center Line		Dimensions (in.)			Bolts No./ Size	Approx. Weight Each (lb.)
			Per Coup Deg.	Pipe (in.)	A	B	C		
1-1/2 x 1-1/4	300	0.12	1°-53'	0.4	2.88	4.55	1.77	2-3/8 x 1-3/4	1.75
2 x 1-1/2	300	0.12	1°-33'	0.4	3.543	5.079	1.85	2-3/8 x 2-3/16	1.95
2-1/2 x 2	300	0.12	1°-33'	0.32	3.976	5.394	1.8	2-3/8 x 2-3/16	2.50
3 x 2	300	0.12	1°-17'	0.26	4.724	6.45	1.89	2-1/2 x 2-1/2	3.64
3 x 2-1/2	300	0.12	1°-17'	0.26	4.72	6.457	1.89	2-1/2 x 2-1/2	3.27
4 x 2	300	0.25	2°-38'	0.55	5.906	7.677	1.929	2-1/2 x 2-1/2	4.74
4 x 2-1/2	300	0.25	2°-38'	0.55	5.906	7.677	1.929	2-1/2 x 2-1/2	4.55
4 x 3	300	0.25	2°-38'	0.55	5.906	7.677	1.929	2-1/2 x 2-1/2	4.16
5 x 4	300	0.25	2°-5'	0.44	6.969	8.74	1.909	2-5/8 x 3-1/2	6.65
6 x 4	300	0.25	1°-44'	0.38	7.992	9.252	1.969	2-1/2 x 3	8.16
8 x 6	300	0.25	1°-15'	0.26	10.394	12.32	2.362	2-5/8 x 4	15.15

PROJECT	APPROVAL STAMP
PROJECT:	<input type="checkbox"/> APPROVED
ADDRESS:	<input type="checkbox"/> APPROVED AS NOTED
ENGINEER:	<input type="checkbox"/> NOT APPROVED
SUBMITTAL DATA:	REMARKS:
NOTES 1:	
NOTES 2:	

FLANGE ADAPTERS STYLE F190

- Conforms to ANSI Class 125 lb. flange/ASTM CL 150
- Available with an external threaded or grooved end
- Made of durable, high-strength ductile iron conforming to ASTM A536, Gr 65-45-12; every lot is metallurgically tested for compliance
- Available with hot dipped galvanized coating for corrosive environments
- Rated for 300 psi

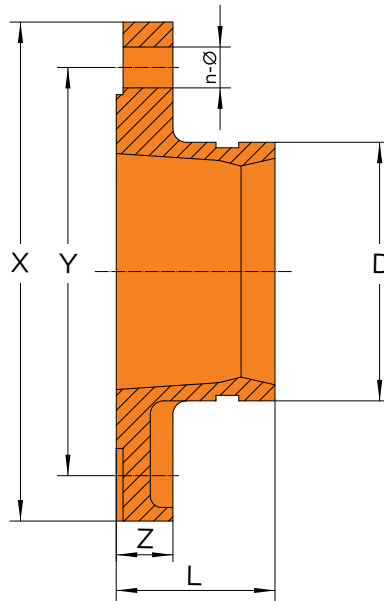

FLANGE ADAPTER - STYLE F190							
Nominal Size (in.)	Pipe OD D (in.)	Working Pressure (psi)	L (in.)	X (in.)	Y (in.)	Z (in.)	Bolt Size (in.) No. - Size
2	2.375	300	2.56	5.98	4.74	0.63	4-5/8
2-1/2	2.875	300	2.56	7.00	5.69	0.69	4-5/8
3	3.500	300	2.56	7.48	6.00	0.75	4-5/8
4	4.500	300	2.76	9.02	7.50	0.96	8-5/8
5	5.562	300	2.76	10.00	8.50	0.96	8-3/4
6	6.625	300	2.76	10.98	9.50	1.10	8-3/4
8	8.625	300	3.23	13.50	11.75	1.11	8-3/4
10	10.750	300	3.35	15.98	14.25	1.18	12-7/8
12	12.750	300	3.54	19.01	17.00	1.26	12-7/8

PROJECT	APPROVAL STAMP
PROJECT:	<input type="checkbox"/> APPROVED
ADDRESS:	<input type="checkbox"/> APPROVED AS NOTED
ENGINEER:	<input type="checkbox"/> NOT APPROVED
SUBMITTAL DATA:	REMARKS:
NOTES 1:	
NOTES 2:	

GROOVED FLANGE ADAPTER STYLE 14



UL Listed
Under File No. EX15592

- **Housing:** Ductile Iron conforming to ASTM A536, Grade 65-45-12
- **Bolts/Nuts:** Zinc electroplated carbon steel oval neck track head bolts conforming to ASTM A183 Grade 2 and SAE J429 Grade 5 with a minimum tensile strength of 110,000 psi. Zinc electroplated carbon steel heavy hex nut conforming to ASTM A536, Grade A.
- **Coatings:** Rust inhibiting orange paint (Standard) or Hot Dipped Galvanized (Optional) conforming to ASTM A153
- **Gasket Material:** Pre-Lubricated Grade "E" EPDM, Approved and Listed for use in Wet or Dry Systems
- **Size:** 2" to 12"
- **Maximum Working Pressure:** 2" to 8" 300 psi, 10" & 12" 175 psi

The Style 14 Flange is designed to connect ANSI Class 125 or Class 150 flange components to grooved piping systems. The use of a Style 20 Gemlock® Steel Adapter is required when used against rubber faced surfaces, serrated or irregular sealing surfaces.

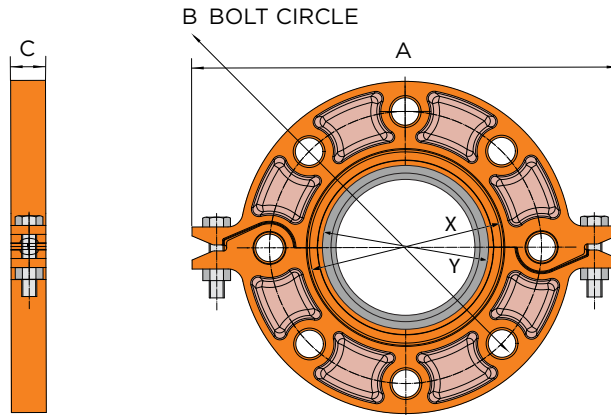

GROOVED FLANGE STYLE 14									
Pipe		Max Working Pressure (psi) *	Sealing Surface (in.)		Dimensions (in.)			Bolts	Approx. Weight Each (lb.)
Nominal Size (in.)	Actual Size (in.)		X Min	Y Max.	A	B (Bolt Circle)	C	No./Size	
2	2.375	300	3.09	2.42	8.11	4.763	0.866	4-5/8 x 2-3/4	3.84
2-1/2	2.875	300	3.58	2.92	9.055	5.511	0.866	4-5/8 x 2-3/4	5.08
3	3.5	300	4.21	3.56	9.527	5.984	0.944	4-5/8 x 2-3/4	5.17
4	4.5	300	5.26	4.57	11.023	7.519	0.944	8-5/8 x 2-3/4	6.46
5	5.563	300	6.41	5.65	12.795	8.503	0.964	8-3/4 x 2-7/8	8.64
6	6.625	300	7.48	6.71	13.583	9.5	0.964	8-3/4 x 3-1/8	8.49
8	8.625	300	9.58	8.7	16.311	11.751	1.102	8-3/4 x 3-1/4	13.48
10	10.75	175	11.65	10.85	20	14.25	1.195	12-7/8 x 3-1/2	24.0
12	12.75	175	13.60	12.90	20.25	17.0	1.25	12-7/8 x4	38.0

PROJECT	APPROVAL STAMP
PROJECT:	<input type="checkbox"/> APPROVED
ADDRESS:	<input type="checkbox"/> APPROVED AS NOTED
ENGINEER:	<input type="checkbox"/> NOT APPROVED
SUBMITTAL DATA:	REMARKS:
NOTES 1:	
NOTES 2:	

FLANGE ADAPTER INSERT STYLE 20

The GemLock®, “Flange Seal Ring Adapter” is designed to be used with the GemLock® Style 14, Grooved Flange. This flange ring is to be installed when using the grooved flange in conjunction with a rubber lined valve or serrated faced flange. It’s purpose is to separate two rubber surfaces from coming in contact with each other, which would lead to joint failure. It is important to note that there should never be a rubber to rubber (or similar material) joint, when installing any type of pipe system.

- Carbon steel conforming to ASTM A 1011
- Zinc electroplated standard carbon steel rings

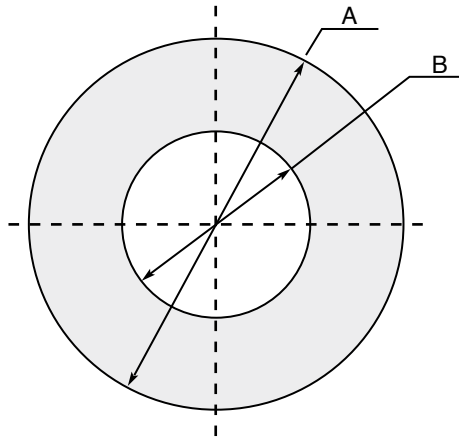

FLANGE ADAPTER INSERT - STYLE 20				
Size (NPS) (in.)	A (OD) (in.)	B (ID) (in.)	Thickness (in.)	Weight (lbs.)
2	4	2.25	.12	.30
2-1/2	4.75	2.75	.12	.40
3	5.25	3.40	.12	.42
4	6.75	4.37	.12	.69
5	7.64	5.43	.12	.75
6	8.63	6.50	.12	.84
8	10.87	8.50	.12	1.20
10	13.27	10.63	.12	1.65
12	16.0	12.65	.12	2.51

PROJECT	APPROVAL STAMP
PROJECT:	<input type="checkbox"/> APPROVED
ADDRESS:	<input type="checkbox"/> APPROVED AS NOTED
ENGINEER:	<input type="checkbox"/> NOT APPROVED
SUBMITTAL DATA:	REMARKS:
NOTES 1:	
NOTES 2:	

MECHANICAL TEE - GROOVED STYLE 15



UL Listed
Under File No. EX15592

- **Housing:** Ductile Iron conforming to ASTM A536, Grade 65-45-12
- **Bolts/Nuts:** Zinc electroplated carbon steel oval neck track head bolts conforming to ASTM A183 Grade 2 and SAE J429 Grade 5 with a minimum tensile strength of 110,000 psi. Zinc electroplated carbon steel heavy hex nut conforming to ASTM A536, Grade A.
- **Coatings:** Rust inhibiting orange paint (Standard) or Hot Dipped Galvanized (Optional) conforming to ASTM A153
- **Gasket Material:** Pre-Lubricated Grade "E" EPDM, Approved and Listed for use in Wet or Dry Systems
- **Gasket Temperature Range:** -40°F to 230°F (Service temperature range)
- **Lubrication:** Supplemental lubricant is recommended for services below 0°F and for all dry pipe systems or systems to be subjected to air tests prior to being filled with water.
- **Sizes:** 2" to 8"
- Maximum Working Pressure: 300 psi

Style 15 Mechanical Tee's are bolted saddle type fittings designed for fast installation of bolted branch outlets as an alternative to welding connections.

Before installing, please read the Installation Instructions.

Obsolete-Style 15 is being replaced by Style 35

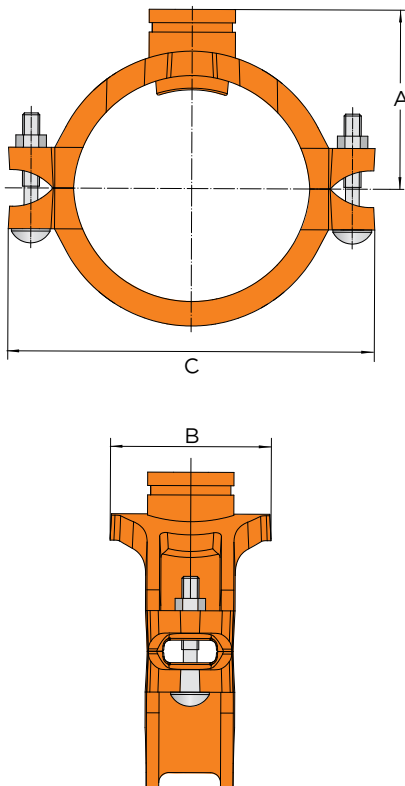

MECHANICAL TEE - GROOVED STYLE 15								
Run Size	Outlet Size (in.)	Max. Working Pressure (psi)*	Hole Diameter (in.)		Grooved Dimensions (in.)			Approx. Weight Each (lb.)
			Hole Saw	Max. Perm.	A	B	C	
2	1-1/4	300	1.75	1.91	2.32	2.71	4.57	1.77
	1-1/2	300	1.75	1.81	2.32	2.71	4.57	1.70
2-1/2	1-1/4	300	2	2.06	2.76	3.307	5.67	2.27
	1-1/2	300	2	2.06	2.76	3.267	5.67	2.47
3	1-1/4	300	2	2.06	2.76	3.23	5.98	2.50
	1-1/2	300	2	2.06	2.76	3.58	5.98	2.89
	2	300	2.5	2.55	3.23	2.4	5.98	3.23
4	1-1/4	300	2	2.06	3.66	3.27	7.32	3.40
	1-1/2	300	2	2.06	3.66	3.62	7.32	3.16
	2	300	2.5	2.55	3.66	3.82	7.4	3.30
	2-1/2	300	3	3.10	3.82	4.84	7.4	4.55
5	3	300	3.5	3.60	3.82	4.92	7.4	4.56
	1-1/2	300	2	2.06	4.21	3.62	8.56	4.27
	2	300	2.5	2.55	4.21	3.82	8.66	4.47
	2-1/2	300	2.75	2.81	4.21	4.84	8.66	5.27
	3	300	3.5	3.60	4.21	5.35	8.66	6.03
6	1-1/4	300	2	2.06	5.04	3.23	9.72	5.50
	1-1/2	300	2	2.06	5.04	3.62	9.72	5.55
	2	300	2.5	2.55	5.04	3.86	9.72	6.18
	2-1/2	300	3.25	3.35	5.04	4.84	9.72	5.32
	3	300	3.5	3.60	5.04	5.35	9.72	7.32
8	4	300	4.5	4.63	5.04	6.18	9.72	7.60
	2	300	2.5	2.55	5.98	5.11	12.2	7.50
	2-1/2	300	2.75	2.81	5.98	5.11	12.2	7.71
	3	300	3.5	3.60	5.98	5.39	12.2	8.3
	4	300	4.5	4.63	5.98	6.38	12.2	9.09

PROJECT	APPROVAL STAMP
PROJECT:	<input type="checkbox"/> APPROVED
ADDRESS:	<input type="checkbox"/> APPROVED AS NOTED
ENGINEER:	<input type="checkbox"/> NOT APPROVED
SUBMITTAL DATA:	REMARKS:
NOTES 1:	
NOTES 2:	

MECHANICAL TEE - GROOVED

STYLE 35



UL Listed
Under File No. EX15592

- **Housing:** Ductile Iron conforming to ASTM A536, Grade 65-45-12
- **Bolts/Nuts:** Zinc electroplated carbon steel oval neck track head bolts conforming to ASTM A183 Grade 2 and SAE J429 Grade 5 with a minimum tensile strength of 110,000 psi. Zinc electroplated carbon steel heavy hex nut conforming to ASTM A536, Grade A.
- **Coatings:** Rust inhibiting orange paint (Standard) or Hot Dipped Galvanized (Optional) conforming to ASTM A153
- **Gasket Material:** Grade "E" EPDM, Approved and Listed for use in Wet or Dry Systems
- **Gasket Temperature Range:** -40°F to 230°F (Service temperature range)
- **Lubrication:** Supplemental lubricant is recommended for services below 0°F and for all dry pipe systems or systems to be subjected to air tests prior to being filled with water.
- **Sizes:** 2" to 8"
- **Maximum Working Pressure:** 300 psi

Style 35 Mechanical Tee's are bolted saddle type fittings designed for fast installation of bolted branch outlets as an alternative to welding connections.

Before installing, please read the Installation Instructions.

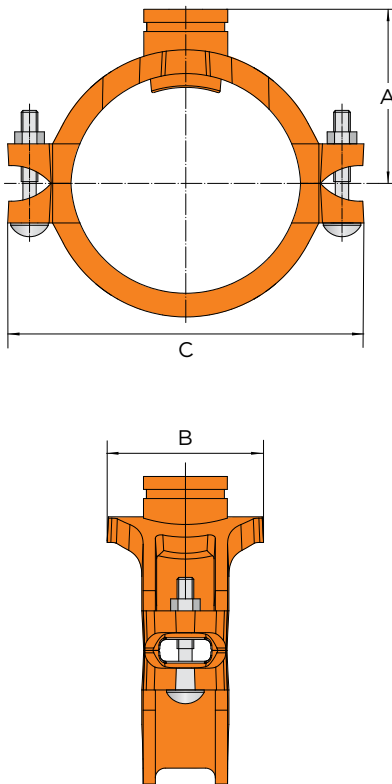

*UL/FM Approvals Pending

MECHANICAL TEE - GROOVED STYLE 35								
Run Size (in.)	Outlet Size (in.)	Max. Working Pressure (psi)*	Hole Diameter (in.)		Grooved Dimensions (in.)			Approx. Weight Each (lb.)
			Hole Saw	Max. Perm.	A	B	C	
2	1-1/4	300	1.75	1.85	2.32	2.72	4.57	1.76
	1-1/2	300	1.75	1.85	2.32	2.72	4.57	1.69
2-1/2	1-1/4	300	2.0	2.06	2.76	3.31	5.67	2.46
	1-1/2	300	2.0	2.13	2.95	3.31	5.67	2.33
	2*	300	2.5	2.63	3.07	3.35	5.35	2.63
3	1-1/4	300	2.0	2.06	2.76	3.23	5.98	2.50
	1-1/2	300	2.0	2.13	2.76	3.58	5.98	2.89
	2	300	2.5	2.63	3.23	3.85	5.98	3.23
4	1-1/4	300	2.0	2.06	3.66	3.27	7.32	3.40
	1-1/2	300	2.0	2.13	3.66	3.27	7.32	3.16
	2	300	2.5	2.63	3.66	3.82	7.40	3.30
	2-1/2	300	2.75	2.88	3.82	4.84	7.40	4.55
5	3	300	3.5	3.55	3.82	4.92	7.40	4.56
	2	300	2.5	2.63	4.21	3.82	8.66	4.47
5	3	300	3.5	3.55	4.21	5.35	8.66	6.03
	1-1/4	300	2.0	2.06	5.04	3.23	9.72	5.50
6	1-1/2	300	2.0	2.13	5.04	3.62	9.72	5.55
	2	300	2.5	2.63	5.04	3.86	9.72	6.18
	2-1/2	300	2.75	2.87	5.04	4.84	9.72	5.32
	3	300	3.5	3.55	5.04	5.35	9.72	7.32
	4	300	4.5	4.63	5.04	6.18	9.72	7.60
	2	300	2.5	2.63	5.98	3.82	12.20	7.50
8	2-1/2	300	2.75	2.87	5.98	5.12	12.20	7.92
	3	300	3.5	3.63	5.98	5.40	12.20	8.30
	4	300	4.5	4.63	5.98	6.38	12.20	9.09

PROJECT	APPROVAL STAMP
PROJECT:	<input type="checkbox"/> APPROVED
ADDRESS:	<input type="checkbox"/> APPROVED AS NOTED
ENGINEER:	<input type="checkbox"/> NOT APPROVED
SUBMITTAL DATA:	REMARKS:
NOTES 1:	
NOTES 2:	

MECHANICAL TEE - THREADED

STYLE 16

- **Housing:** Ductile Iron conforming to ASTM A536, Grade 65-45-12
- **Bolts/Nuts:** Zinc electroplated carbon steel oval neck track head bolts conforming to ASTM A183 Grade 2 and SAE J429 Grade 5 with a minimum tensile strength of 110,000 psi. Zinc electroplated carbon steel heavy hex nut conforming to ASTM A536, Grade A.
- **Coatings:** Rust inhibiting orange paint (Standard) or Hot Dipped Galvanized (Optional) conforming to ASTM A153
- **Gasket Material:** Pre-Lubricated Grade "E" EPDM, Approved and Listed for use in Wet or Dry Systems
- **Gasket Temperature Range:** -40°F to 230°F (Service temperature range)
- **Lubrication:** Supplemental lubricant is recommended for services below 0°F and for all dry pipe systems or systems to be subjected to air tests prior to being filled with water.
- **Sizes:** 1-1/2" to 8"
- **Threads:** NPT per ANSI/ASME B1.20.1
- **Maximum Working Pressure:** 300 psi



UL Listed
Under File No. EX15592

Style 16 Mechanical Tee's are bolted saddle type fittings designed for fast installation of bolted branch outlets as an alternative to welding connections.

Before installing, please read the Installation Instructions.

Obsolete-Style 16 is being replaced by Style 36

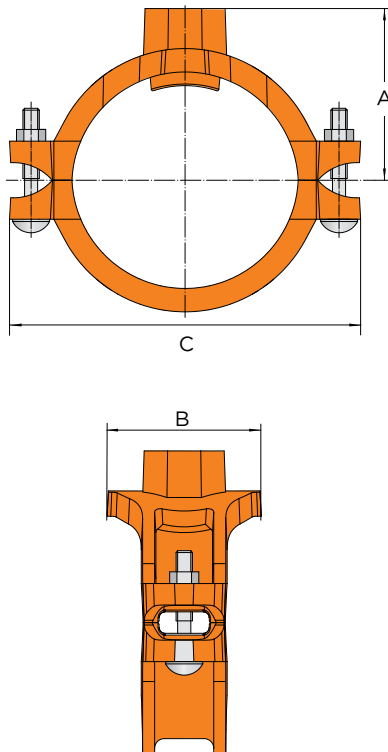

MECHANICAL TEE - THREADED STYLE 16								
Run Size (in.)	Outlet Size (in.)	Max. Working Pressure (psi)*	Hole Diameter (in.)		Threaded Dimensions (in.)			Approx. Weight Each (lb.)
			Hole Saw	Max. Perm.	A	B	C	
1-1/2	1	300	1.5	1.56	2.20	2.40	4.40	1.49
	2	300	1.5	1.56	2.36	2.71	4.567	1.53
2	1-1/4	300	2.0	2.06	2.36	2.71	4.567	1.66
	1-1/2	300	2.0	2.06	2.36	2.71	4.567	1.88
2-1/2	1	300	1.5	1.56	2.76	3.03	5.67	1.98
	1-1/4	300	2	2.06	2.76	3.27	5.67	2.36
2-1/2	1-1/2	300	2	2.06	2.76	3.27	5.67	2.33
	1	300	1.5	2.06	3.23	3.03	5.98	2.48
3	1-1/4	300	2	2.06	3.23	3.27	5.98	2.47
	1-1/2	300	2	2.06	3.23	3.62	5.98	2.60
3	2	300	2.5	2.55	3.23	3.89	5.98	2.96
	1	300	1.5	1.56	3.43	3.03	6.77	2.86
4	1-1/4	300	2	2.06	3.43	3.27	6.77	3.25
	1-1/2	300	2	2.06	3.43	3.62	6.77	3.25
4	2	300	2.5	2.55	3.43	3.82	6.77	3.55
	2-1/2	300	3.0	3.60	3.10	4.41	6.77	3.59
4	3	300	3.5	2.55	3.60	4.9	6.77	4.84
	1-1/2	300	2	2.06	3.94	3.62	8.27	3.65
5	2	300	2.5	2.55	3.94	3.82	8.27	3.89
	2-1/2	300	3.25	3.35	3.94	4.84	8.27	6.0
5	3	300	3.5	3.60	3.94	4.84	8.27	6.04
	1-1/4	300	2	2.06	4.61	3.27	9.53	5.32
6	1-1/2	300	2	2.06	4.61	3.62	9.53	5.80
	2	300	2.5	2.55	4.61	3.82	9.53	5.96
6	2-1/2	300	3.25	3.35	4.61	4.84	9.53	5.31
	3	300	3.5	3.60	4.61	5.35	9.53	7.32
8	2-1/2	300	3.25	3.35	5.75	5.11	12.2	7.48
	3	300	3.5	3.60	5.75	5.39	12.2	8.3
8	4	300	4.5	4.63	5.75	6.38	12.2	10.17

PROJECT	APPROVAL STAMP
PROJECT:	<input type="checkbox"/> APPROVED
ADDRESS:	<input type="checkbox"/> APPROVED AS NOTED
ENGINEER:	<input type="checkbox"/> NOT APPROVED
SUBMITTAL DATA:	REMARKS:
NOTES 1:	
NOTES 2:	

MECHANICAL TEE - THREADED STYLE 36



UL Listed
Under File No. EX15592

- **Housing:** Ductile Iron conforming to ASTM A536, Grade 65-45-12
- **Bolts/Nuts:** Zinc electroplated carbon steel oval neck track head bolts conforming to ASTM A183 Grade 2 and SAE J429 Grade 5 with a minimum tensile strength of 110,000 psi. Zinc electroplated carbon steel heavy hex nut conforming to ASTM A536, Grade A.
- **Coatings:** Rust inhibiting orange paint (Standard) or Hot Dipped Galvanized (Optional) conforming to ASTM A153
- **Gasket Material:** Grade "E" EPDM, Approved and Listed for use in Wet or Dry Systems
- **Gasket Temperature Range:** -40°F to 230°F (Service temperature range)
- **Lubrication:** Supplemental lubricant is recommended for services below 0°F and for all dry pipe systems or systems to be subjected to air tests prior to being filled with water.
- **Sizes:** 2" to 8"
- **Threads:** NPT per ANSI/ASME B1.20.1
- **Maximum Working Pressure:** 300 psi

Style 36 Mechanical Tee's are bolted saddle type fittings designed for fast installation of bolted branch outlets as an alternative to welding connections.

Before installing, please read the Installation Instructions.

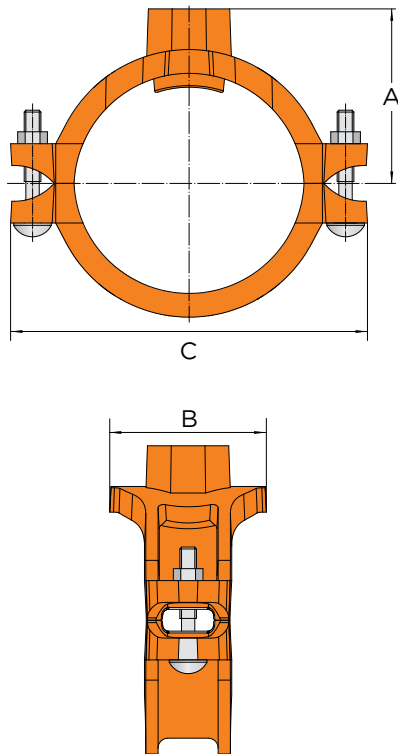

*UL/FM Approvals Pending

MECHANICAL TEE - THREADED STYLE 36								
Run Size (in.)	Outlet Size (in.)	Max Working Pressure (psi)*	Hole Diameter (in.)		Threaded Dimensions (in.)			Approx. Weight Each (lb.)
			Hole Saw	Max. Perm.	A	B	C	
2	1	300	1.5	1.63	2.36	2.72	4.57	1.45
	1-1/4	300	1.75	1.85	2.36	2.72	4.57	1.66
	1-1/2	300	1.75	1.85	2.36	2.72	4.57	1.88
2-1/2	1	300	1.5	1.63	2.60	3.07	5.70	1.98
	1-1/4	300	2.0	2.13	2.76	3.27	5.67	2.36
	1-1/2	300	2.0	2.13	2.36	3.27	5.67	2.33
	2*	300	2.5	2.63	3.07	3.35	5.35	2.88
3	1	300	1.5	1.63	3.23	3.03	5.98	2.48
	1-1/4	300	2.0	2.13	3.23	3.27	5.98	2.47
	1-1/2	300	2.0	2.13	3.23	3.62	5.98	2.60
	2	300	2.5	2.63	3.23	3.90	5.98	2.96
4	1	300	1.5	1.63	3.66	3.03	7.40	2.86
	1-1/4	300	2.0	2.13	3.66	3.27	7.40	3.25
	1-1/2	300	2.0	2.13	3.66	3.62	7.40	3.25
	2	300	2.5	2.63	3.66	3.82	7.40	3.55
	2-1/2	300	2.75	2.87	3.66	4.41	7.40	3.59
	3	300	3.5	3.63	3.66	4.92	7.40	4.84
5	1-1/2	300	2.0	2.13	3.94	3.62	8.66	3.65
	2	300	2.5	2.63	4.21	3.82	8.66	3.89
	3	300	3.5	3.63	4.21	5.35	8.66	6.04
6	1-1/4	300	2.0	2.13	4.72	3.23	9.72	5.32
	1-1/2	300	2.0	2.13	4.72	3.62	9.72	5.80
	2	300	2.5	2.63	4.72	3.86	9.72	5.96
	2-1/2	300	2.75	2.87	4.72	4.84	9.72	5.31
	3	300	3.5	3.55	4.72	5.35	9.72	7.32
8	4	300	4.5	4.63	4.72	6.18	9.72	7.60
	4	300	4.5	4.63	5.75	6.38	12.21	10.17

PROJECT	APPROVAL STAMP
PROJECT:	<input type="checkbox"/> APPROVED
ADDRESS:	<input type="checkbox"/> APPROVED AS NOTED
ENGINEER:	<input type="checkbox"/> NOT APPROVED
SUBMITTAL DATA:	REMARKS:
NOTES 1:	
NOTES 2:	

GROOVED FITTINGS SHORT PATTERN STYLES F105, F106, F107, F135



UL Listed
Under File No. EX15591

- **Fittings:** Ductile Iron conforming to ASTM A536, Grade 65-45-12
- **Coatings:** Rust inhibiting orange paint (Standard) or Hot Dipped Galvanized (Optional) conforming to ASTM A153
- **Sizes:** 1-1/2" to 8"
- **Maximum Working Pressure:** 300 psi

Short pattern products are all full flow design, specifically for use in Fire Protection applications.

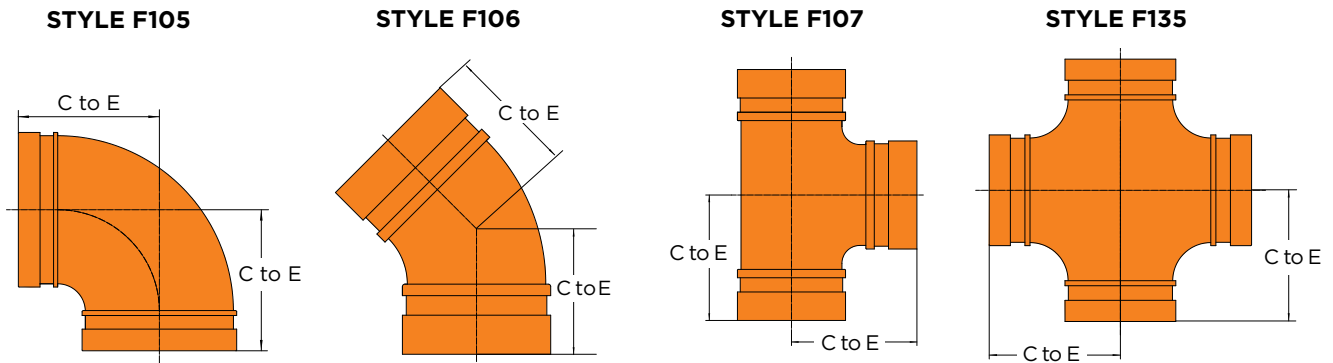

GROOVED FITTINGS - SHORT PATTERN									
Pipe		90° Elbow No. F105		45° Elbow No. F106		Equal Tee No. F107		Cross No. F135	
Nominal Size (in.)	Actual Size (in.)	C to E (in.)	Approx. Wgt. Ea. (lb.)	C to E (in.)	Approx. Wgt. Ea. (lb.)	C to E (in.)	Approx. Wgt. Ea. (lb.)	C to E (in.)	Approx. Wgt. Ea. (lb.)
1-1/2	1.9	2.362	1.01	1.73	.78	2.362	1.34	2.75	2.5
2	2.375	2.755	1.24	2.00	1.20	2.755	1.98	2.75	2.49
2-1/2	2.875	2.992	2.03	2.24	1.63	2.992	2.82	2.99	3.19
3	3.5	3.368	2.53	2.52	2.38	3.386	3.90	3.38	5.09
4	4.5	3.996	3.74	3.00	3.84	3.996	5.72	3.99	7.22
5	5.563	4.803	7.20	3.28	5.74	4.803	9.52	4.80	7.23
6	6.625	5.61	9.06	3.51	8.11	5.5	14.13	5.5	15.97
8	8.625	6.889	20.52	4.25	14.27	6.889	27.07	6.88	28.66

PROJECT	APPROVAL STAMP
PROJECT:	<input type="checkbox"/> APPROVED
ADDRESS:	<input type="checkbox"/> APPROVED AS NOTED
ENGINEER:	<input type="checkbox"/> NOT APPROVED
SUBMITTAL DATA:	REMARKS:
NOTES 1:	
NOTES 2:	

STANDARD GROOVED FITTINGS STYLES 100, 101, 102, 103, 110 & 150



UL Listed
Under File No. EX15591

- **Fittings:** Ductile Iron conforming to ASTM A536, Grade 65-45-12
- **Coatings:** Rust inhibiting orange paint (Standard) or Hot Dipped Galvanized (Optional) conforming to ASTM A153
- **Sizes:** 1" to 12"
- **Maximum Working Pressure:** 300 psi

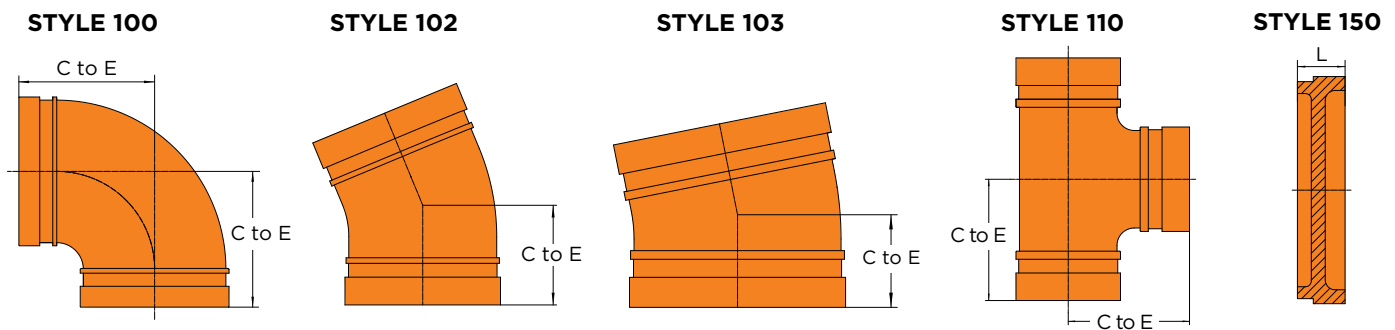

STANDARD GROOVED FITTINGS											
Pipe		90° Elbow No. 100		22-1/2° Elbow No. 102		11-1/4° Elbow No. 103		Equal Tee No. 110		End Cap No. 150	
Nominal Size (in.)	Actual Size (in.)	C to E (in.)	Approx. Wgt. Ea. (lb.)	C to E (in.)	Approx. Wgt. Ea. (lb.)	C to E (in.)	Approx. Wgt. Ea. (lb.)	C to E (in.)	Approx. Wgt. Ea. (lb.)	L (in.)	Approx. Wgt. Ea. (lb.)
1	1.315	2.24	.85	1.61	.45	1.38	.42	2.24	1.45	0.96	.25
1-1/4	1.66	2.755	1.17	1.732	.80	1.38	0.55	2.755	1.52	0.96	.33
1-1/2	1.9	2.755	1.17	1.732	.84	1.38	0.63	2.755	1.74	0.96	0.44
2	2.375	3.257	2.25	2.0	1.14	1.38	0.82	3.267	2.5	0.96	0.61
2-1/2	2.875	3.74	2.76	2.0	1.50	1.5	1.22	3.74	3.73	0.96	0.85
3	3.5	4.251	3.44	2.24	2.53	1.5	1.62	4.251	6.24	0.96	1.01
4	4.5	5.0	5.32	2.87	3.91	1.89	2.63	5.0	8.70	0.99	1.42
5	5.563	5.51	8.0	2.87	5.10	2.0	3.90	5.51	12.44	0.99	2.80
6	6.625	6.496	14.31	3.11	7.16	2.0	4.78	6.496	18.21	0.99	4.40
8	8.625	7.755	21.63	3.86	11.88	2.0	7.10	7.755	33.25	1.181	9.30
10	10.75	8.464	37.04	4.37	14.0	2.13	14.5	8.464	46.35	1.26	9.33
12	12.75	9.645	57.25	4.88	22.0	2.25	25.5	9.645	59.50	1.26	13.25

PROJECT	APPROVAL STAMP
PROJECT:	<input type="checkbox"/> APPROVED
ADDRESS:	<input type="checkbox"/> APPROVED AS NOTED
ENGINEER:	<input type="checkbox"/> NOT APPROVED
SUBMITTAL DATA:	REMARKS:
NOTES 1:	
NOTES 2:	

STANDARD REDUCERS CONCENTRIC - STYLE 140 ECCENTRIC - STYLE 145



UL Listed
Under File No. EX15591

- **Fittings:** Ductile Iron conforming to ASTM A536, Grade 65-45-12
- **Coatings:** Rust inhibiting orange paint (Standard) or Hot Dipped Galvanized (Optional) conforming to ASTM A153
- **Sizes Standard Concentric Reducer:** 1-1/2" to 10"
Sizes Eccentric Reducer: 3" to 10"
- **Maximum Working Pressure:** 300 psi

STYLE 140

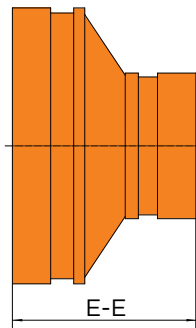

STYLE 145

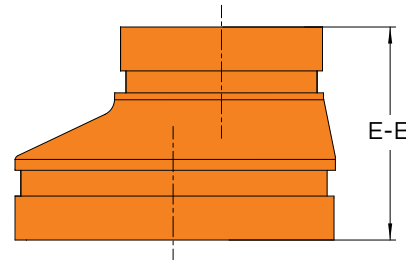

CONCENTRIC REDUCER - NO. 140			CONCENTRIC REDUCER - NO. 140		
Nominal Size (in.)	E to E (in.)	Approx. Wgt. Ea. (lb.)	Nominal Size (in.)	E to E (in.)	Approx. Wgt. Ea. (lb.)
1-1/2 x 1-1/4	2.52	.60	6 x 2-1/2	4.02	4.10
2 x 1	2.52	.72	6 x 3	4.02	4.12
2 x 1-1/4	2.52	.69	6 x 4	4.02	4.63
2 x 1-1/2	2.52	.72	6 x 5	4.02	4.35
2-1/2 x 1-1/4	2.52	.91	8 x 3	5	7.71
2-1/2 x 1-1/2	2.52	.92	8 x 4	5	6.76
2-1/2 x 2	2.52	1.02	8 x 5	5	7.71
3 x 1	2.52	1.10	8 x 6	5	8.15
3 x 1-1/4	2.52	1.15	10 x 4	5.98	20.0
3 x 1-1/2	2.52	1.16	10 x 6	5.98	14.48
3 x 2	2.52	1.21	10 x 8	5.98	14.16
3 x 2-1/2	2.52	1.25			
4 x 1	3.00	2.2			
4 x 2	3.00	2.4			
4 x 2-1/2	3.00	2.7			
4 x 3	3.00	2.8			
5 x 2	3.5	3.8			
5 x 4	3.5	2.95			
6 x 2	4.02	4.36			

ECCENTRIC REDUCER - NO. 145		
Nominal Size (in.)	E to E (in.)	Approx. Wgt. Ea. (lb.)
3 x 2	2.52	1.8
3 x 2-1/2	2.52	1.6
4 x 2	3.00	2.6
4 x 2-1/2	3.00	2.8
4 x 3	3.00	3.3
5 x 2-1/2	3.50	10.8
5 x 3	3.50	11
5 x 4	3.50	5.1
6 x 2-1/2	4.02	14.1
6 x 3	4.02	14.9
6 x 4	4.02	6.6
6 x 5	4.02	9.4
8 x 3	5.00	22.0
8 x 4	5.00	22.9
8 x 5	5.00	26.5
8 x 6	5.00	30.8
10 x 6	5.98	36.5
10 x 8	5.98	38

PROJECT	APPROVAL STAMP
PROJECT:	<input type="checkbox"/> APPROVED
ADDRESS:	<input type="checkbox"/> APPROVED AS NOTED
ENGINEER:	<input type="checkbox"/> NOT APPROVED
SUBMITTAL DATA:	REMARKS:
NOTES 1:	
NOTES 2:	

STANDARD DRAIN ELBOW



STYLE F100D

- **Cast Fittings:** Ductile Iron conforming to ASTM A536, Grade 65-45-12
- **Fabricated Fittings:** Carbon Steel Schedule 10
- **Coatings:** Rust inhibiting orange paint (Standard) or Hot Dipped Galvanized (Optional) conforming to ASTM A153
- **Cast Fitting Sizes:** 2" to 8"
- **Threads:** NPT per ANSI/ASME B1.20.1
- **Maximum Working Pressure:** 300 psi

Drain Elbow comes standard with 1" female NPT outlet per ASME B1.20.1

DRAIN ELBOW - STANDARD STYLE F100D

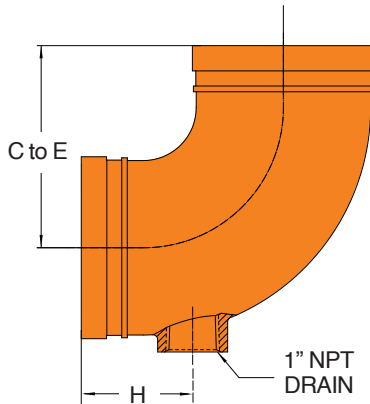

DRAIN ELBOW - STANDARD STYLE F100D				
Pipe		Dimensions (in.)		Approx. wgt. Ea. (lb.)
Nominal Size (in.)	Actual Size (in.)	C to E	H	
2	2.375	3.27	2.75	3.8
2-1/2	2.875	3.75	2.75	5.2
3	3.500	4.25	2.75	5.3
4	4.500	5.00	2.75	8.8
6	6.625	6.50	2.75	18.7
8	8.625	7.8	2.75	31.0

DRAIN TEE STYLE 115D

- Fabricated from ASTM A53 SCH 40 pipe
- Standard grooves to AWWA C606
- Threads are MNPT
- Available with hot dipped galvanized coating for corrosive environments
- Rated for 300 psi

STYLE 115D

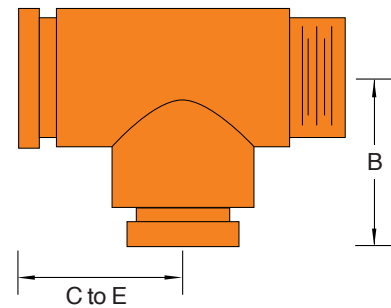

DRAIN TEE - STYLE 115D			
Nominal Size (in.)	Dimensions		Weight (lbs.)
	C-E	B	
1-1/4	2-3/4	2-3/4	1.4
1-1/2	2-3/4	2-3/4	1.6

PROJECT	APPROVAL STAMP
PROJECT:	<input type="checkbox"/> APPROVED
ADDRESS:	<input type="checkbox"/> APPROVED AS NOTED
ENGINEER:	<input type="checkbox"/> NOT APPROVED
SUBMITTAL DATA:	REMARKS:
NOTES 1:	
NOTES 2:	

STANDARD DRAIN CAP STYLE F155D



UL Listed
Under File No. EX15591

- **Cast Fittings:** Ductile Iron conforming to ASTM A536, Grade 65-45-12
- **Fabricated Fittings:** Carbon Steel Schedule 10
- **Coatings:** Rust inhibiting orange paint (Standard) or Hot Dipped Galvanized (Optional) conforming to ASTM A153
- **Cast Fitting Sizes:** 2" to 8"
- **Fabricated Fitting Sizes:** 1-1/4" to 1-1/2"
- **Threads:** NPT per ANSI/ASME B1.20.1
- **Maximum Working Pressure:** 300 psi

Drain Cap comes standard with 1" female NPT outlet per ASME B1.20.1 sizes 1-1/4" to 6" and 2" Female NPT outlet per ASME B1.20.1 on 8.

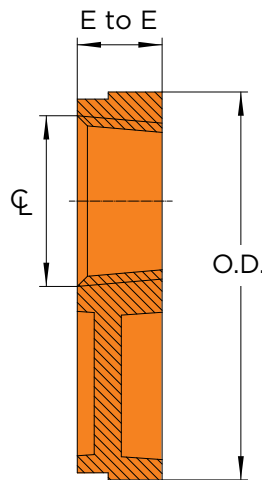

FIGURE F155D CAP				
Nominal Size	O.D.	End to End	Outlet Size	Approx. wgt. Ea.
in./DN	in.	in.	in.	lbs.
1-1/4	1.660	1-1/4	1	0.4
1-1/2	1.900	1-1/4	1	0.5
2	2.375	1	1	0.5
2-1/2	2.875	1	1	0.7
3	3.500	1	1	1.1
4	4.500	1-1/8	1	2.8
5	5.563	1-1/8	1	4.0
6	6.625	1-5/16	1	6.0
8	8.625	1-1/2	2	12.5

PROJECT	APPROVAL STAMP
PROJECT:	<input type="checkbox"/> APPROVED
ADDRESS:	<input type="checkbox"/> APPROVED AS NOTED
ENGINEER:	<input type="checkbox"/> NOT APPROVED
SUBMITTAL DATA:	REMARKS:
NOTES 1:	
NOTES 2:	

REDUCING TEE - SHORT PATTERN STYLE 115



UL Listed
Under File No. EX15591

- **Fittings:** Ductile Iron conforming to ASTM A536, Grade 65-45-12
- **Coatings:** Rust inhibiting orange paint (Standard) or Hot Dipped Galvanized (Optional) conforming to ASTM A153
- **Sizes:** 2" to 10"
- **Maximum Working Pressure:** 300 psi

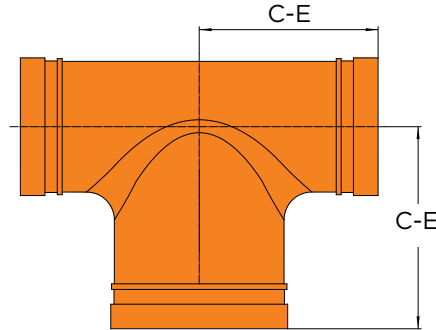

REDUCER TEE - NO. 115 (Add after part number the letters TF for internal or TM for external threaded outlet)		
Nominal Size (in.)	C to E (in.)	Approx. Wgt. Ea. (lb.)
2-1/2 x 2-1/2 x 2	3.00	5.1
3 x 3 x 2	3.39	8.4
3 x 3 x 2-1/2	3.39	8.6
4 x 4 x 2	4.00	10.4
4 x 4 x 2-1/2	4.00	11.4
4 x 4 x 3	4.00	11.6
5 x 5 x 2	4.80	14.5
5 x 5 x 3	4.80	15.4
5 x 5 x 4	4.80	16.1
6 x 6 x 2	5.51	26.4
6 x 6 x 2-1/2	5.51	26.5
6 x 6 x 3	5.51	26.5
6 x 6 x 4	5.51	29.3
6 x 6 x 5	5.51	30.9
8 x 8 x 2	6.90	33.5
8 x 8 x 2-1/2	6.90	39.0
8 x 8 x 3	6.90	33.6
8 x 8 x 4	6.90	47.4
8 x 8 x 5	6.90	48.3
10 x 10 x 4	9.0	79.4
10 x 10 x 5	9.0	78.9
10 x 10 x 6	9.0	78.3
10 x 10 x 8	9.0	77.2

PROJECT	APPROVAL STAMP
PROJECT:	<input type="checkbox"/> APPROVED
ADDRESS:	<input type="checkbox"/> APPROVED AS NOTED
ENGINEER:	<input type="checkbox"/> NOT APPROVED
SUBMITTAL DATA:	REMARKS:
NOTES 1:	
NOTES 2:	

90° ADAPTER ELL STYLE 105TL

- Transitions from grooved to threaded connection
- Direct connection to sprinkler heads
- Available in rust inhibitive black paint & galvanized finish
- Made of durable, high-strength ductile iron conforming to ASTM A536, Gr 65-45-12; every lot is metallurgically tested for compliance
- Rated for 500 psi



UL Listed
Under File No. EX15591

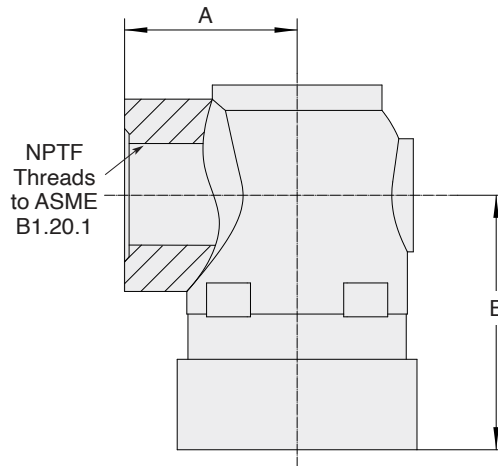

90° ADAPTER ELL			
Nominal Size (in.)	Max. Work Pressure (psi)	Dimensions (in.)	
		A	B
1-1/4 x 1/2	500	1.77	1.20
1-1/4 x 3/4	500	1.77	1.20
1-1/4 x 1	500	1.91	1.24
1-1/2 x 1/2	500	1.77	1.32
1-1/2 x 3/4	500	1.77	1.32
1-1/2 x 1	500	1.91	1.32
2 x 1/2	500	1.75	1.57
2 x 3/4	500	1.77	1.57
2 x 1	500	1.91	1.63
2-1/2 x 1/2	500	1.75	1.75
2-1/2 x 3/4	500	1.75	1.75
2-1/2 x 1	500	1.91	1.81

PROJECT	APPROVAL STAMP
PROJECT:	<input type="checkbox"/> APPROVED
ADDRESS:	<input type="checkbox"/> APPROVED AS NOTED
ENGINEER:	<input type="checkbox"/> NOT APPROVED
SUBMITTAL DATA:	REMARKS:
NOTES 1:	
NOTES 2:	

TEE LOCK STYLE 13*



UL Listed
Under File No. EX15592

- **Housing:** Ductile Iron conforming to ASTM A536, Grade 65-45-12
- **U-Bolts/Nuts:** Zinc electroplated carbon steel oval U-bolt conforming SAE J429 Grade 2. Zinc electroplated carbon steel hex flanged lock nuts conforming to ASTM A536, Grade A.
- **Coatings:** Uncoated bare ductile iron (Standard) or Hot Dipped Galvanized (Optional) conforming to ASTM A153
- **Gasket Material:** Grade "E" EPDM, Approved and Listed for use in Wet or Dry Systems
- **Gasket Temperature Range:** -40°F to 230°F (Service temperature range)
- **Sizes:** 1-1/4" to 2-1/2"
- **Threads:** NPT per ANSI/ASME B1.20.1
- **Maximum Working Pressure:** 300 psi

Style 13 Tee Locks are designed for fast installation of bolted branch outlets.

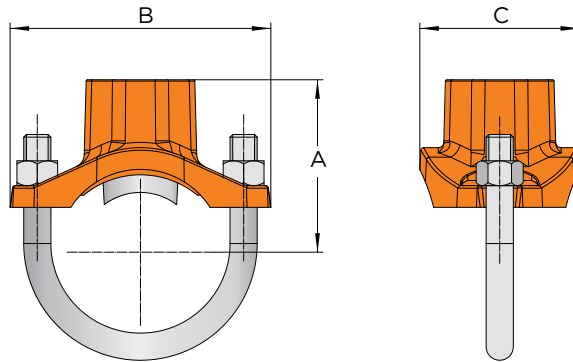

*** Due to updated UL requirements the Style 13 is being replaced with the GemLock® Style 13A**

TEE LOCK STYLE 13						
Nominal Size (in.)	Max. Working Pressure (psi)	Hole Saw (in.)	Dimensions (in.)			Weight (lbs.)
			A	B	C	
1-1/4 x 1/2	300	1-3/16	1.693	3.543	2.205	0.78
1-1/4 x 3/4	300	1-3/16	1.772	3.543	2.205	0.85
1-1/4 x 1	300	1-3/16	1.969	3.543	2.20	0.95
1-1/2 x 1/2	300	1-3/16	1.693	3.661	2.323	0.78
1-1/2 x 3/4	300	1-3/16	2.126	3.661	2.323	0.89
1-1/2 x 1	300	1-3/16	2.283	3.661	2.323	0.98
2 x 1/2	300	1-3/16	2.126	3.780	2.323	0.82
2 x 3/4	300	1-3/16	2.205	3.780	2.323	0.90
2 x 1	300	1-3/16	2.598	3.780	2.323	1.02
2-1/2 x -1/2	300	1-3/16	2.362	4.331	2.323	0.90
2-1/2 x 3/4	300	1-3/16	2.480	4.331	2.323	0.93
2-1/2 x 1	300	1-3/16	2.756	4.331	2.323	0.95

PROJECT	APPROVAL STAMP
PROJECT:	<input type="checkbox"/> APPROVED
ADDRESS:	<input type="checkbox"/> APPROVED AS NOTED
ENGINEER:	<input type="checkbox"/> NOT APPROVED
SUBMITTAL DATA:	REMARKS:
NOTES 1:	
NOTES 2:	

TEE LOCK STYLE 13A*



- **Housing:** Ductile Iron conforming to ASTM A536, Grade 65-45-12
- **U-Bolts/Nuts:** Zinc electroplated carbon steel oval U-bolt conforming SAE J429 Grade 2. Zinc electroplated carbon steel hex flanged lock nuts conforming to ASTM A536, Grade A.
- **Coatings:** Uncoated bare ductile iron (Standard) or Hot Dipped Galvanized (Optional) conforming to ASTM A153
- **Gasket Material:** Grade "E" EPDM, Approved and Listed for use in Wet or Dry Systems
- **Gasket Temperature Range:** -40°F to 230°F (Service temperature range)
- **Sizes:** 1-1/4" to 2-1/2"
- **Threads:** NPT per ANSI/ASME B1.20.1
- **Maximum Working Pressure:** 300 psi

Style 13A Tee Locks are designed for fast installation of bolted branch outlets.

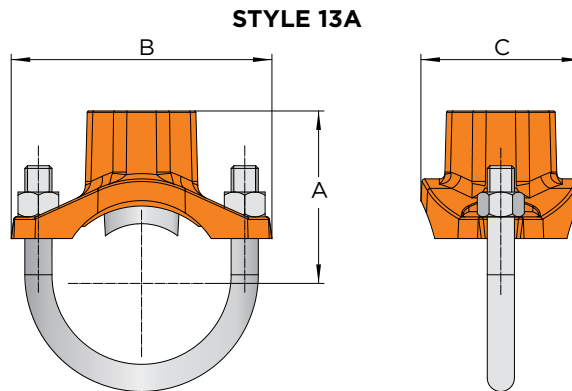

* Designed to meet UL's most recent flow requirements

TEE LOCK STYLE 13A							
Nominal Size (in.)	Max. Working Pressure (psi)	Hole Saw (in.)		Dimensions (in.)			Weight (lbs.)
		Min.	Max.	A	B	C	
1-1/4 x 1/2	300	1-5/16	1-3/8	1.693	3.543	2.205	0.78
1-1/4 x 3/4	300	1-5/16	1-3/8	1.772	3.543	2.205	0.85
1-1/4 x 1	300	1-5/16	1-3/8	1.969	3.543	2.20	0.95
1-1/2 x 1/2	300	1-5/16	1-3/8	1.693	3.661	2.323	0.78
1-1/2 x 3/4	300	1-5/16	1-3/8	2.126	3.661	2.323	0.89
1-1/2 x 1	300	1-5/16	1-3/8	2.283	3.661	2.323	0.98
2 x 1/2	300	1-5/16	1-3/8	2.126	3.780	2.323	0.82
2 x 3/4	300	1-5/16	1-3/8	2.205	3.780	2.323	0.90
2 x 1	300	1-5/16	1-3/8	2.598	3.780	2.323	1.02
2-1/2 x -1/2	300	1-5/16	1-3/8	2.362	4.331	2.323	0.90
2-1/2 x 3/4	300	1-5/16	1-3/8	2.480	4.331	2.323	0.93
2-1/2 x 1	300	1-5/16	1-3/8	2.756	4.331	2.323	0.95

PROJECT	APPROVAL STAMP
PROJECT:	<input type="checkbox"/> APPROVED
ADDRESS:	<input type="checkbox"/> APPROVED AS NOTED
ENGINEER:	<input type="checkbox"/> NOT APPROVED
SUBMITTAL DATA:	REMARKS:
NOTES 1:	
NOTES 2:	