

STANDARD DRAIN ELBOW STYLE F100D & F105D

- Provides 1" NPT drain required on some fire protection stand pipes
- Smoother flow than fabricated segmented steel elbows
- Made of ductile iron conforming to ASTM A536
- Every lot is metallurgically tested to insure compliance
- Available with hot dipped galvanized coating
- Pressure rating of 300 psi



UL Listed
Under File No. EX15591

FLOW DATA Equivalent Feet of Straight Pipe		
Nominal Size (In.)	90° Elbow	
	STD	Short Pattern
2	3.5	3.2
2-1/2	4.3	3.9
3	5.0	4.8
4	6.8	6.5
6	10.0	10.0

Flow data is based upon the pressure drop of Sch. 40 pipe

Drain Elbow-Standard Style F100D

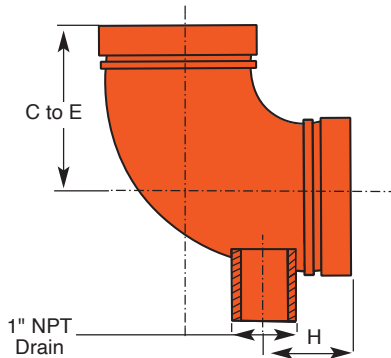

Drain Elbow-Short Pattern Style F105D

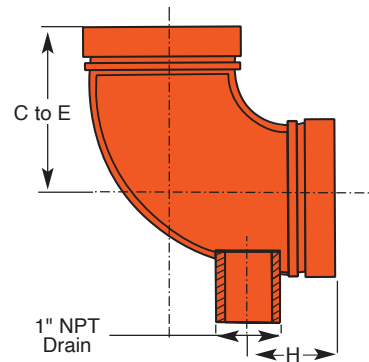

DRAIN ELBOW - STANDARD - STYLE F100D				
Pipe		Dimensions (In.)		Approx. Wgt. Ea. (Lb.)
Nominal Size (In.)	Actual Size (In.)	C to E	H	
2	2.375	3.27	2.75	3.8
2-1/2	2.875	3.75	2.75	5.2
3	3.500	4.25	2.75	5.3
4	4.500	5.00	2.75	8.8
6	6.625	6.50	2.75	18.7

DRAIN ELBOW - SHORT PATTERN - STYLE F105D				
Pipe		Dimensions (In.)		Approx. Wgt. Ea. (Lb.)
Nominal Size (In.)	Actual Size (In.)	C to E	H	
2	2.375	2.75	2.00	1.0
2-1/2	2.875	3.00	2.00	1.7
3	3.500	3.39	2.00	2.5
4	4.500	4.00	2.00	5.3
6	6.625	5.50	2.00	13.9

PROJECT	APPROVAL STAMP
PROJECT:	<input type="checkbox"/> APPROVED
ADDRESS:	<input type="checkbox"/> APPROVED AS NOTED
ENGINEER:	<input type="checkbox"/> NOT APPROVED
SUBMITTAL DATA:	REMARKS:
NOTES 1:	
NOTES 2:	