

MECHANICAL TEES

STYLE 15 GROOVED

Mechanical Branchlet provides a direct branch connection at any location along the pipe run without welding. A hole cut along the center line of pipe will receive the hole locator collar to secure the outlet.

A pressure responsive EPDM gasket molded to suit the run pipe insures leak tight joints. Cross type connections can be made utilizing upper housings only. Available with hot dipped galvanized coating.



UL Listed
Under File No. EX15592

Style 15

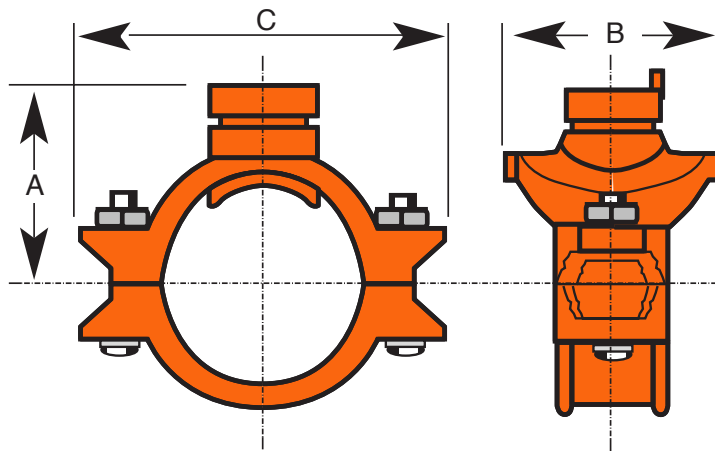

Run Size (In.)	Outlet Size (In.)	Max. Working Pressure (psi)*	Hole Diameter		Grooved Dimensions (In.)			Approx. Weight Ea. Grooved (Lb.)
			Hole Saw (In.)	Max. Perm. (In.)	A	B	C	
2	1-1/4	300	2.0	2.06	2.24	2.835	4.57	2.27
	1-1/2	300	2.0	2.13	2.40	2.835	4.57	2.46
2-1/2	1-1/4	300	2.0	2.06	2.402	3.268	5.354	2.27
	1-1/2	300	2.0	2.13	2.402	3.268	5.354	2.47
3	1-1/4	300	2.0	2.06	2.874	3.23	5.98	2.50
	1-1/2	300	2.0	2.13	2.874	3.58	5.98	2.89
	2	300	2.5	2.63	3.071	3.85	5.98	3.23
4	1-1/4	300	2.0	2.06	3.425	3.27	6.772	3.40
	1-1/2	300	2.0	2.13	3.425	3.622	6.772	3.16
	2	300	2.5	2.63	3.425	3.82	6.772	3.30
	2-1/2	300	3.25	3.35	3.74	4.84	7.087	4.55
	3	300	3.5	3.55	3.82	4.92	7.087	4.56

MECHANICAL TEE STYLE 15 GROOVED



Style 15

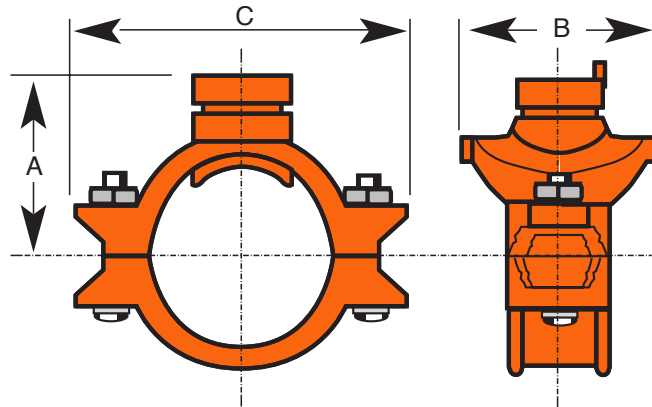

Run Size (In.)	Outlet Size (In.)	Max Working Pressure (psi)*	Hole Diameter		Grooved Dimensions (In.)			Approx. Weight Ea.
			Hole Saw (In.)	Max. Perm. (In.)	A	B	C	Grooved (Lb.)
5	1-1/2	300	2.0	2.13	4.21	3.62	8.66	4.27
	2	300	2.5	2.63	4.21	3.82	8.66	4.47
	2-1/2	300	2.75	2.88	4.21	4.84	8.66	5.27
	3	300	3.5	3.55	4.21	5.35	8.66	6.03
6	1-1/4	300	2.0	2.06	5.04	3.23	9.72	5.50
	1-1/2	300	2.0	2.13	5.04	3.62	9.72	5.55
	2	300	2.5	2.63	5.04	3.86	9.72	6.18
	2-1/2	300	3.25	3.35	5.04	4.84	9.72	5.32
	3	300	3.5	3.55	5.04	5.35	9.72	7.32
	4	300	4.5	4.63	5.04	6.18	9.72	7.60
8	2	300	2.5	2.63	5.748	3.82	11.89	7.50
	2-1/2	300	3.25	3.35	5.748	5.12	11.89	7.71
	3	300	3.5	3.63	5.98	5.40	11.89	8.30
	4	300	4.5	4.63	6.024	6.38	11.89	9.09

NOTES: –Bolts and Nuts are galvanized. * – Maximum pressure including surges and maximum end loads from all internal and external forces, to which a joint could be subject under normal working conditions. This rating provides a nominal safety factor of 1.5 times working pressure based on standard weight steel pipe. Maximum working pressure may be subjected to a one time field test of 1.5 times the figures indicated. Refer to installations and groove specifications when assembling any grooved product. EPDM gasket is supplied as standard. For other gaskets contact us.

PROJECT	APPROVAL STAMP
PROJECT:	<input type="checkbox"/> APPROVED
ADDRESS:	<input type="checkbox"/> APPROVED AS NOTED
ENGINEER:	<input type="checkbox"/> NOT APPROVED
SUBMITTAL DATA:	REMARKS:
NOTES 1:	
NOTES 2:	