

FLEXIBLE COUPLING STYLE 12

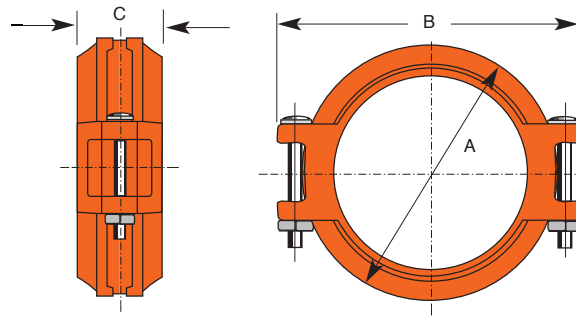

- Provides joint flexibility required in some piping systems
- Conforms to the requirements of ANSI B31.1 Power Piping Code; ANSI B31.9 Building Service Pipe Code and NFPA 13 Sprinkler Systems
- Available with hot dipped galvanized coating as optional
- Supplied with pre-lubed gasket
- Provided with EPDM Gasket suitable to 230°F



Pipe		Max. Working Pressure (psi)*	Allow Pipe End Separation (In.)	Max Deflection from Center Line		Dimensions (In.)			Approx. Weight Each (lb.)
Nominal Size (In.)	Actual Size (In.)			Per Coup. Deg.	Pipe (In.)	A	B	C	
1	1.315	300	0.1	5° - 26'	1.14	2.36	3.86	1.71	1.2
1-1/4	1.66	300	0.1	4° - 19'	0.9	2.63	4.17	1.732	1.30
1-1/2	1.9	300	0.1	3° - 46'	0.79	2.87	4.25	1.732	1.27
2	2.375	300	0.1	3° - 1'	0.62	3.43	4.84	1.732	1.48
2-1/2	2.875	300	0.1	2° - 29'	0.52	3.94	5.43	1.732	1.71
3	3.5	300	0.1	2° - 3'	0.43	4.61	6.35	1.77	2.44
4	4.5	300	0.16	3° - 11'	0.67	5.47	7.48	1.929	2.89
5	5.563	300	0.16	2° - 3 5'	0.54	6.61	8.58	1.929	3.58
6	6.625	300	0.16	2° - 10'	0.46	7.82	9.49	1.929	4.73
8	8.625	300	0.19	1° - 40'	0.34	9.96	12.60	2.323	7.91
10	10.75	300	0.19	0° - 95'	0.13	12.48	15.79	2.48	16.95
12	12.75	300	.20	0° - 23'	0.12	14.76	17.91	2.52	24.0

NOTES: Allowable pipe end separation is for cut groove pipe, for roll groove, figures will be one-half of the values listed at time of initial pressurization. – Bolts and Nuts are galvanized. * – Maximum pressure including surges and maximum end loads from all internal and external forces, to which a joint could be subject under normal working conditions. This rating provides a nominal safety factor of 1.5 times working pressure based on standard weight steel pipe. Maximum working pressure may be subjected to a one time field test of 1.5 times the figures indicated. Refer to installations and groove specifications when assembling any grooved product. EPDM gasket is supplied as standard. For other gaskets contact us.

PROJECT	APPROVAL STAMP
PROJECT:	<input type="checkbox"/> APPROVED
ADDRESS:	<input type="checkbox"/> APPROVED AS NOTED
ENGINEER:	<input type="checkbox"/> NOT APPROVED
SUBMITTAL DATA:	REMARKS:
NOTES 1:	
NOTES 2:	